

# STATUS OF THE FRM-II HOT NEUTRON SOURCE

C. MÜLLER and E. GUTSMIEDL

*ZBE FRM-II*

*Technische Universität München, Lichtenbergstraße 1, 85747 Garching – Germany*

*and*

A. SCHEUER

*Institut für Kerntechnik und Strahlenschutz (IKS)*

*TÜV Rheinland/Berlin-Brandenburg e.V., Am Grauen Stein, 51105 Köln – Germany*

## Abstract

The new research reactor FRM-II will be equipped with a hot neutron source. This secondary source will shift a part of the thermal neutron energy spectrum in the D<sub>2</sub>O moderator to energies from 0.1 to 1 eV.

The hot neutron source consists of a graphite cylinder (200 mm Ø, 300 mm high), which is heated by gamma radiation up to a maximum temperature of about 2400°C. The graphite cylinder is surrounded by a high-temperature insulation of carbon fiber, to achieve this high temperature. We have accomplished mock-up tests of the carbon fiber in a high temperature furnace, to investigate the insulation properties of the material.

The graphite cylinder and the insulation are covered with two vessels made out of Zircaloy 4. The space between the vessels is filled with helium. The hot neutron source is permanent under control by pressure and temperature measurements. The temperature inside the graphite cylinder will be measured by a purpose-built noise thermometer due to the extremely harsh environment conditions (temperature and nuclear radiation).

The hot neutron source is designed and manufactured according to the general specification basic safety and to the German nuclear atomic rules (KTA). The source will be installed in year 2001.

## 1. Introduction

At the new high flux reactor FRM-II a neutron single crystal diffractometer called HEiDi is supposed to take over a large number of tasks in the area of diffraction with hot neutrons. Therefore a hot neutron source (HNS) will be installed at the FRM-II to produce hot neutrons at energies of 0.1 up to 1 eV.

The principle of the HNS is to shift the Maxwellian spectrum of the reactor neutrons to higher energies. This will be achieved by a hot moderator, which is placed in the D<sub>2</sub>O - reflector tank close to the thermal neutron flux maximum. Thermal neutrons will be rethermalized in the hot moderator. A beam tube will guide hot neutrons emerging from the HNS to the experiment.

This paper describes design and status of the HNS at the FRM-II.

## 2. Design of the HNS

The essential part of the HNS is the hot moderator - a cylinder made of nuclear-grade graphite with a density of  $1,82 \text{ g/cm}^3$ . The graphite cylinder has 200 mm in diameter and is 300 mm high. The volume of graphite cylinder is approximately  $10 \text{ dm}^3$ . Apart from well known behaviour in high irradiation fields, graphite as moderator material was also chosen because of its ability up to  $2800^\circ\text{C}$  in inert-atmosphere.

The graphite cylinder will be heated by the nuclear radiation of the reactor core up to high temperatures. Therefore, complex electrical system necessary for heating can be avoided. The temperature of the graphite cylinder depends on the gas filled in the vessel. On a first calculation the temperature can be varied between  $2000^\circ\text{C}$  and  $2400^\circ\text{C}$  using helium, neon or by evacuating the vessel. There are no problems with helium and neon due to neutron activation.

To achieve these high temperatures the moderator needs careful thermal insulation. Therefore, the cylinder is surrounded by several layers of high temperature carbon fiber. Each layer of the carbon fiber is 10 mm thick. The layers have a density of  $0,09 \text{ g/cm}^3$  and a thermal conductivity of  $0,07 \text{ W/mK @ } 20^\circ\text{C}$ . A second type of insulation is placed below the graphite cylinder. This insulation is a rigid hemisphere made of carbon bounded carbon fiber and supports the cylinder in the vessel. The density of this material is about  $0,16 \text{ g/cm}^3$ .

Both types of insulation also have the task to fix the graphite cylinder in the middle and to avoid the contact with the "cold" walls.

A schematic cut showing the graphite cylinder, the high thermal insulation and the source vessels is given in Figure 1.

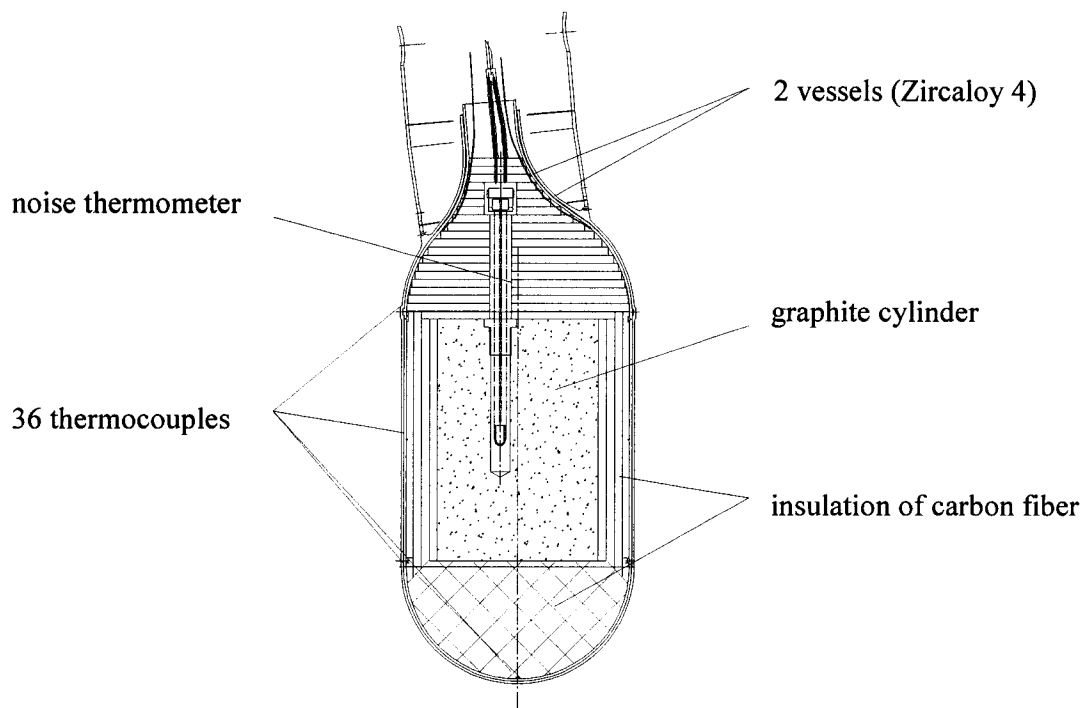

Figure 1: Hot neutron source vessels with graphite cylinder and insulation

There are no problems of incompatibility between insulation and moderator at high temperature because they are the same material. However, graphite reacts at moderately high temperatures with oxygen (in air) and water. Therefore, the graphite cylinder and the insulation are double contained

within two independent vessels. Each vessel of 3 mm thickness is manufactured out of Zircaloy 4. The diameter of the outer vessel is about 300 mm. The small space between the vessels will be filled with helium of 3 bar and permanently controlled. Hence there are two barriers which will safely separate the hot graphite cylinder from air and water.

Figure 2 shows all parts of the HNS in the reactor pool. The in-pile section is tilted 5° against the vertical axis and is located in the D<sub>2</sub>O - reflector tank. The hot moderator in the in-pile section has a distance of 420 mm from the reactor core axis and is close to the thermal neutron flux maximum.

The external instrument container is also placed in the reactor pool. All necessary valves, pressure gauges and an ion pump are located in the external instrument container. Instrument container and in-pile section are connected by tubes.

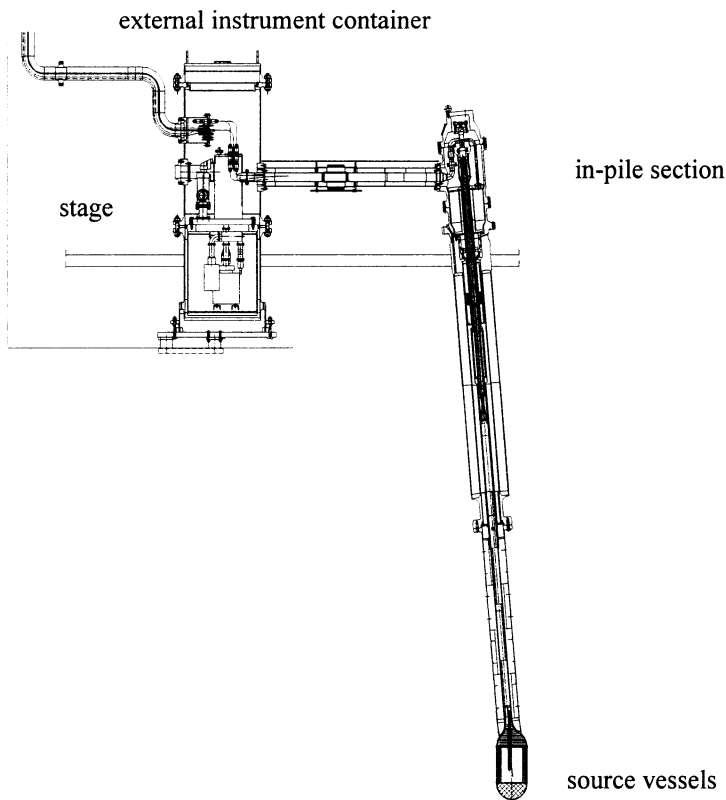

Figure 2: In-pile section and the external instrument container of the HNS

The remaining instruments, the gas supply and the control system of the HNS are placed outside of the reactor pool.

### 3. Instrumentation

All pressures and temperatures of the HNS are measured and monitored permanently. Differences to normal pressures are registered and reported. If a leakage in one of the vessels occurs, the reactor will be shut down automatically.

There are 36 chromel–alumel thermocouples spread over the inner vessel (fig. 1), which will control the wall temperature. All temperatures above 200°C will force the personal to shut down the reactor.

It is quite difficult to measure the temperature in the graphite cylinder due to the extremely harsh environment conditions e.g. high graphite temperature, chemical reactivity and nuclear radiation. Under these conditions thermocouples and pyrometer are not suitable. Therefore a noise thermometer is installed to measure the temperature in the hot graphite cylinder (fig. 1). The noise thermometer is a contact thermometer and is not affected by changes of the sensor. This thermometer measures the white noise of an electrical resistance and determines the absolute temperature [1]. The noise sensor, built of graphite, was developed and tested at the Technischen Universität München. The data acquisition system for the noise thermometer is delivered from the Forschungszentrum Jülich, ZEL - Germany.

#### **4. Mock-up Tests**

Calculation with finite element method were made to get the temperature distribution over the HNQ. Also thermal stress analysis was done to find condition for burdening of the source vessels.

Apart from theoretical calculation we have accomplished mock-up tests in a high-temperature furnace. The furnace is purpose-built to investigate properties of carbon fiber insulation and the graphite cylinder. The furnace consists of two vessels of stainless steel. The space between the vessels is water cooled. The inner vessel contains a graphite block and the carbon insulation. The graphite block and the insulation consist of the same materials and have the same sizes as in the real HNS. Hence, the tests are comparable to the HNS. The furnace is heated electrically by a graphite heater and reaches temperature values up to 2300°C.

Both results of the mock-up tests and the finite element calculations are quite good. The agreement between experimental and theoretical results is satisfying.

#### **5. Conclusion**

The hot neutron source is designed and manufactured according to the general specification basic safety and the German nuclear atomic rules (KTA). The mounting of the hardware components of the HNS into the reactor facility will be finished in summer of 2001. After this the test operation phase will begin.

#### **6. References**

[1] Brix, H.: "Noise Thermometers" in: Sensors, Vol.4, VCH Verlag, 1990, Chapter 6