



# BRIEF DESCRIPTION TO DESIGN CHARACTERISTICS OF CARR

**Yuan Luzheng Ke Guotu Jin Huajin**

China Institute of Atomic Energy  
Beijing, China

RRFM/IGORR JOINT MEETING, LYON, FRANCE,  
March 11-15, 2007



# CONTENTS

- 1. Introduction**
- 2. Characteristics of core structure design in CARR**
- 3. Application design of CARR**
- 4. Conclusion**
- 5. Status of CARR project**



# 1. Introduction

CIAE: synthetic nuclear scientific center in China

Two old research reactors in CIAE:

HWRR: Heavy Water Research Reactor built in 1958

SPR: Swimming Pool Reactor built in 1964

Both are in extended service and facing the aging problems

Out of service successively in the near future

An urgent task to construct a new research reactor for CIAE !

Now such a research reactor with higher performance, called China Advanced Research Reactor (CARR) has been under constructed in CIAE site



# Introduction

CARR: a beam type RR,  
power 60 MW,  
an inverse neutron trap compact core,  
surrounded by a heavy water reflector,  
maximum unperturbed thermal neutron  
flux peak of about  $8 \times 10^{14} \text{n/cm}^2 \cdot \text{s}$  ,  
nine tangent horizontal neutron beam  
channels available for experiments,  
25 vertical irradiation channels



# Introduction

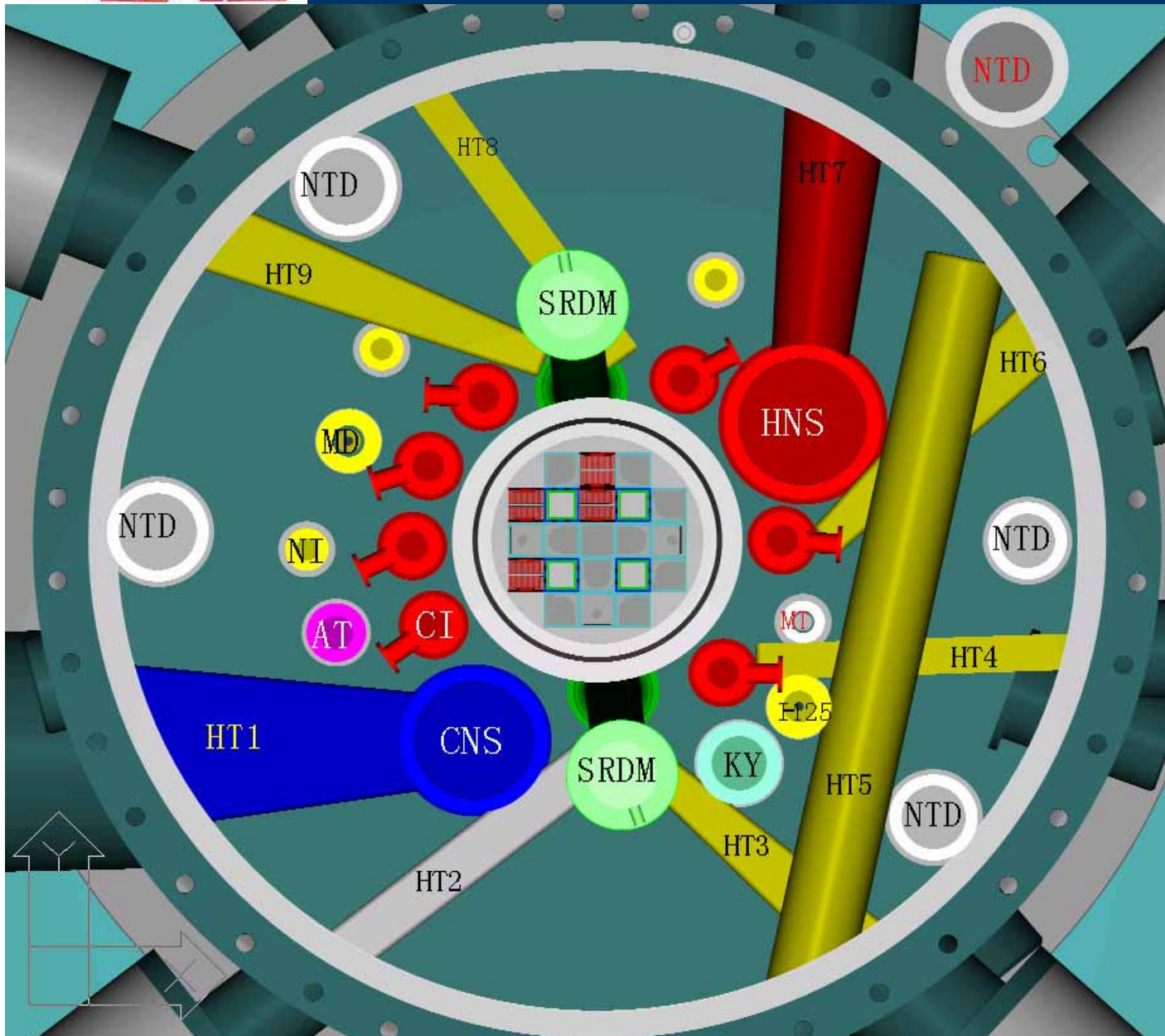

## *Vertical channels :*

*CNS: Cold neutron source*

*HNS: Hot neutron source*

*CI,NI: isotope hole*

*MT: Material irradiation  
monitoring hole*

*NTD: NTD silicon hole*

*AT: NAA hole*

*SRDM: Safety rod drive  
mechanism*

## *Horizontal beam tubes:*

*HT1: Cold neutron source  
beam tube*

*HT2: Multi-filtration neutron  
beam tube*

*HT3, HT4, HT6, HT8, HT9:  
Thermal neutron beam tube*

*HT5: Long tangential beam  
tube*

*HT7: Hot neutron source beam  
tube*



# Introduction

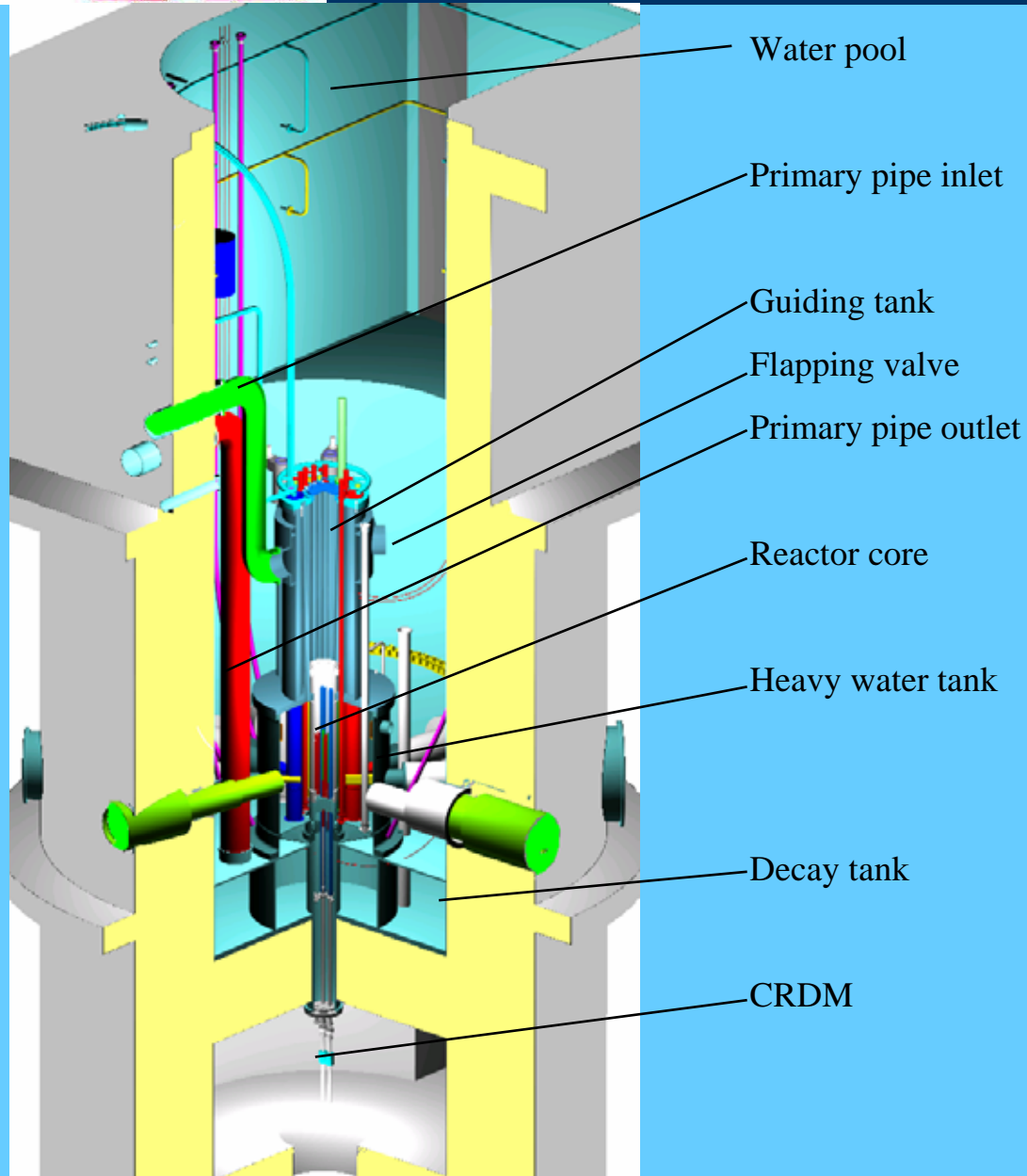

main application for CARR covers:

Neutron scattering experiments,

Radioisotope irradiation,

NAA application,

material irradiation tests,

NTD silicon preparation,

NPP fuel engineering tests





# CARR's main parameters

Reactor power	60MW
The maximum unperturbed thermal neutron flux	
Core center	$1 \times 10^{15}$ n/cm <sup>2</sup> •s
D2O reflector	$8 \times 10^{14}$ n/cm <sup>2</sup> •s
Primary coolant total flow	2400m <sup>3</sup> /h
Inlet pressure, core coolant	0.850MPa
Inlet temperature, core coolant	35°C
Outlet temperature, core coolant	55.4°C
Mean coolant speed, core fuel	10.1m/s
Core height	850mm
Core equivalent diameter	399mm



# CARR's main parameters

Core lattice pitch	77.2mm×77.2mm
Diameter, core housing vessel	479mm
Diameter, heavy water tank	2248 mm×24 mm
Height, heavy water tank	2000mm
Total worth of control rods	36.37% ( $\Delta k/k$ )
The maximum excess reactivity	20.07% ( $\Delta k/k$ )
Thickness of fuel meat	0.6mm
Thickness of fuel cladding	0.38mm
Uranium load at beginning	55.53kg
Mean power density in core	564 W/ cm <sup>3</sup>
Mean unload fuel burn-up	32.15 %





## 2. Characteristics of core structure design in CARR

CARR is a multipurpose and high performance RR. The compact core structure, lots of experimental channels

—————→ difficulties structure layout

Three highs: uranium density, heat flux, high coolant speed

—————→ difficulties in thermal hydraulic design

Meanwhile, the reactor site being located at the suburbs of Beijing, the capital and political center of China

—————→ outside emergency activity is absolutely not allowed.

All these factors result in the characteristics for CARR design



## 2.1 Inverse neutron trap design

Inverse neutron trap design, a world trend of core design for RRs.

Distinguishing features: getting high thermal neutron flux in heavy water reflector, achieving the space separation of neutron spectrum and obtaining more space available for neutron applications.

The quality factor, merit of a RR, defined as the ratio of maximum thermal neutron flux to reactor power, reaches about  $1.33 \times 10^{13} \text{ n}/(\text{cm}^2 \cdot \text{s} \cdot \text{MW})$  which belongs to the rank of some high performance RRs in the world.



## 2.2 Never lead to uncovered core design

- The core of CARR is immersed in a 15-meter depth water pool and seated on a decay tank located at the pool bottom.
- Processing rooms of primary cooling system are all located above the position of core top elevation.
- These rooms are airtight and volume limited.
- Even if LOCA happen, the processing rooms would be filled with leaking water, the core fuel would never be uncovered due to lowering of pool water level, and several meters thick water would still cover the core

To assure the reactor core not lead to bare!

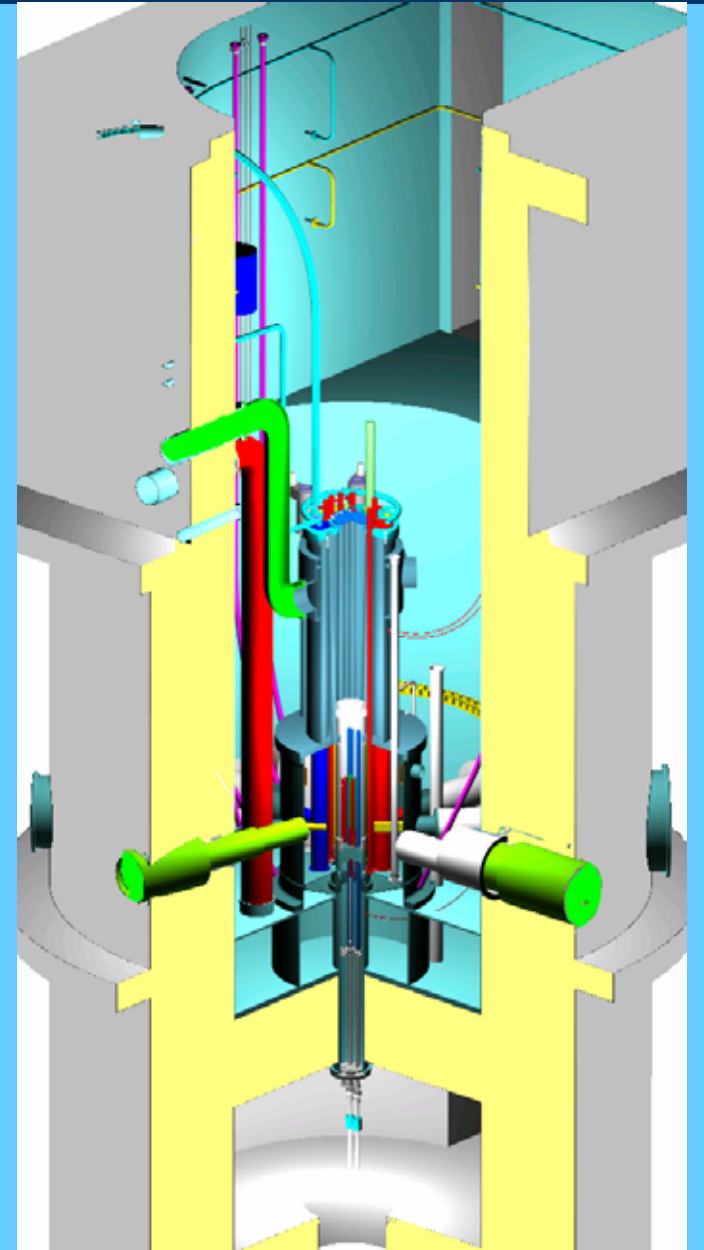



## 2.3 Layout for decay tank

Generally decay tank for RRs is

arranged at the outlet of core coolant

The decay tank in CARR is seated on

the pool bottom directly located

under the core and heavy water tank.

This layout is favorable to meet:

- requirements of thermal hydraulic condition
- effectively save the building occupation

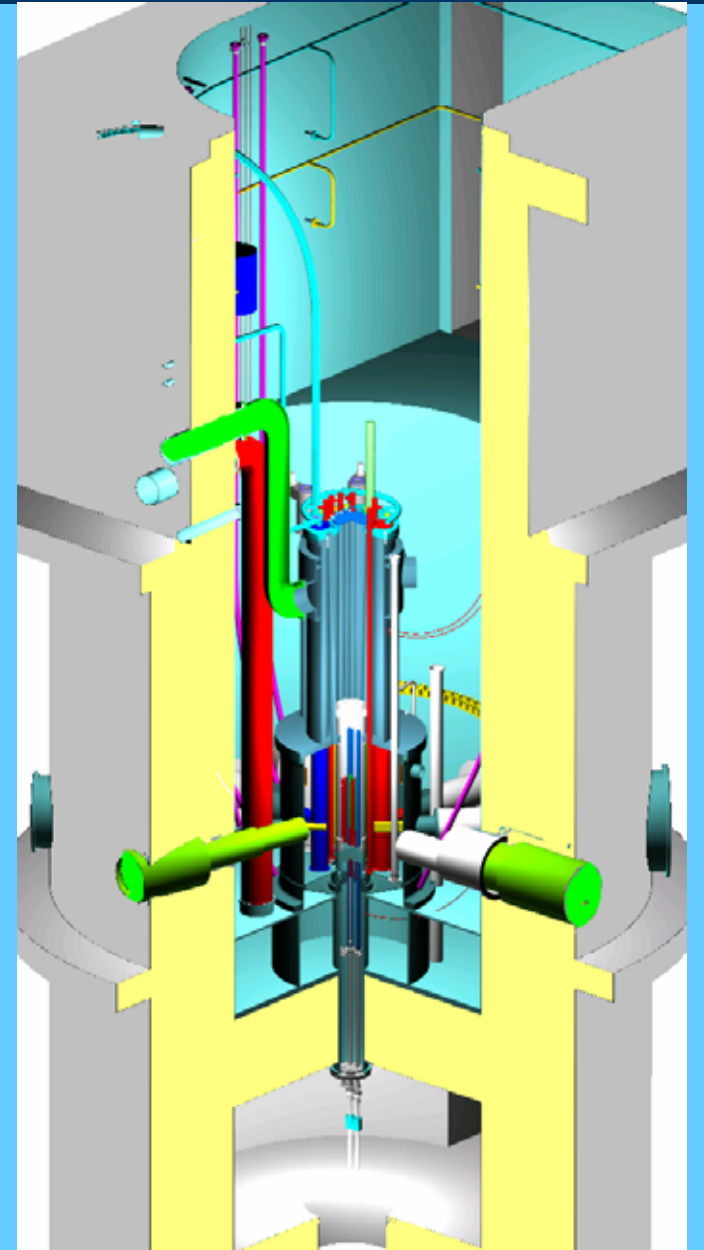



## 2.4 New type fuel adopted

The  $U_3Si_2$ -Al dispersion is adopted by CARR.

Aluminum alloy, 6061 Al, is adopted as cladding material which combines well with meat  $U_3Si_2$ -Al.

Plain plate MTR type fuel assembly is adopted for CARR.

The fuel assembly is similar to that of JRR-3M and JMTR

For China the first time to design and fabricate such high density uranium fuel assembly



## fuel assembly engineering tests

Round the fuel assembly design and fabrication a series of engineering verification tests covers:

- ◆ Heat transfer and critical heat flux experiments under high heat load conditions;
- ◆ Whole core flow induced vibration and flow distribution tests;
- ◆ Hydraulic properties study on fuel assemblies;
- ◆ Off-pile flushing test for fuel assembly;
- ◆ Irradiation tests for both fuel assembly and small fuel element specimen;





# fuel assembly engineering tests

All these tests have proved:

The design and fabrication of CARR fuel and fuel assembly are reasonable and successful



## 2.5 Digital technology used in I&C system

All digital technology is adopted in I&C system for CARR. It covers:

- supervision and control system with a distributed computer system
- reactor protection system with nuclear measuring channel and T-H processing channel and others;
- ATWS mitigation system and
- reactor automatic starting-up and power regulating system.



## 2.6 Diversity design of driven mechanism for control rods

4 control rods : as compensating and regulating rods, similar to that of JRR-3M in JAERI

Two safety rods : adopt hydraulic driven mechanism design

To avoid occurring the common cause failure hence enhancing the reactor safety



## 2.7 Artifice design for CNS moderator cell structure

Liquid hydrogen moderator in CARR's CNS.

If simple two-phase thermal siphon structure adopted, heat removal very difficult.

Especially, CARR is a multipurpose research reactor

It is requested: reactor be on running while the CNS be off.

Under condition of “both reactor and CNS are on”:

CNS can provide stable cold neutrons stream

Under condition of “reactor running while CNS off”:

no damage would happen for the moderator cell

**Two-phase thermal siphon heat removal + helium gas directly cooling mode** in CARR CNS has been adopted



## CNS moderator cell structure

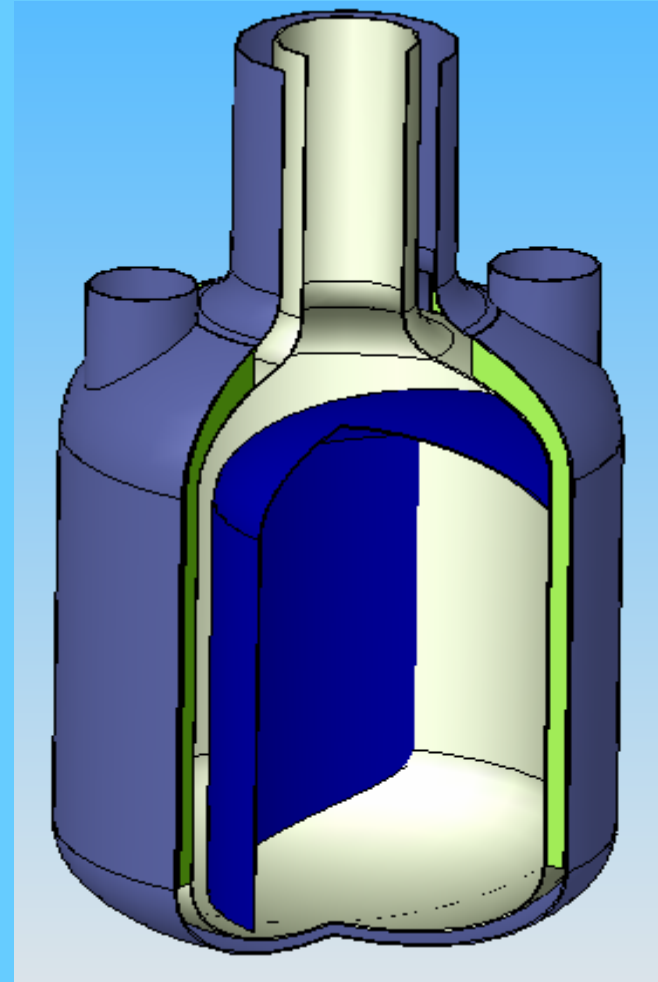
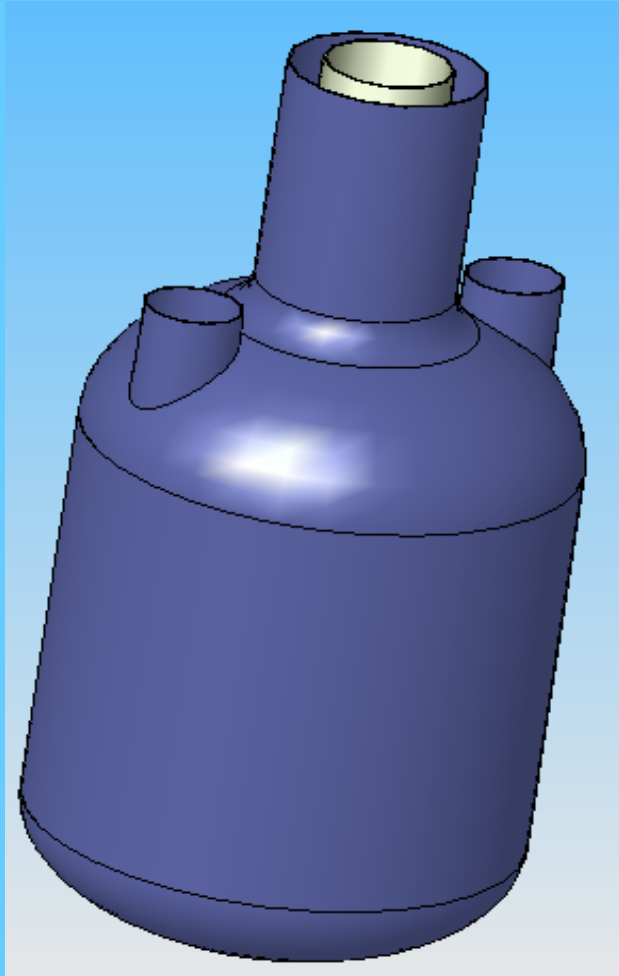



## 2.8 Passive design for natural circulation flapping valves

Two passive flapping valves are mounted on the top side of the guiding tank.

Under the condition of both primary cooling loop and emergency cooling system being failure, core residual heat can be removed by natural circulation through these two flapping valves.

It will take the great role to protect the fuel assembly from boiling burnt due to its passive function.





## Structure of natural circulation flapping valve

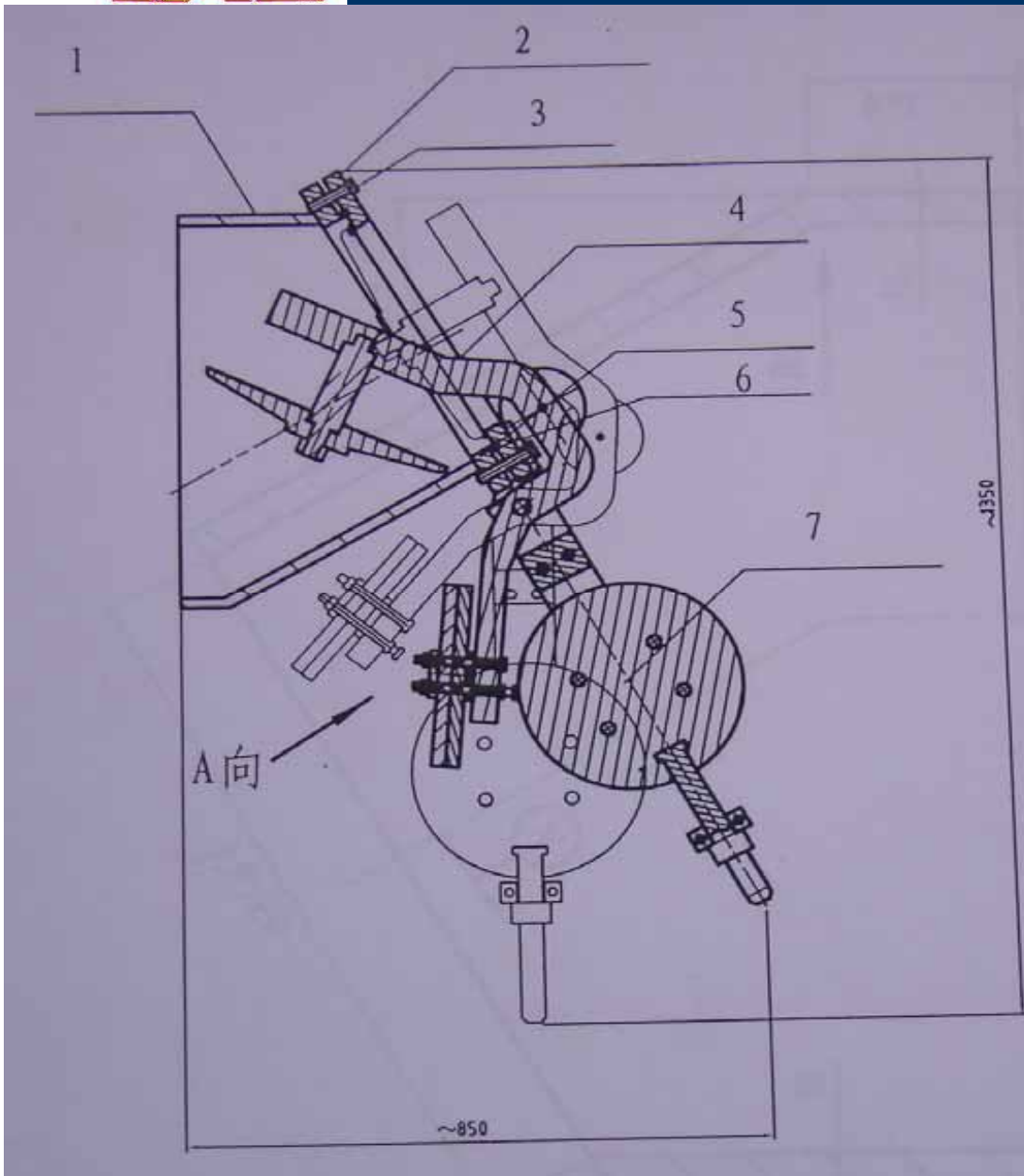

**It will take the great role to protect the fuel assembly from boiling burnt due to its passive function.**



## 2.9 Warmer pool layer to depress radiation level

When the reactor is running, the radioactivity in pool water will follow the heat convection to reach pool surface

—————→ increasing the radiation level in operating hall.

In CARR, a warmer water layer has been designed.



## Warmer pool layer to depress radiation level (Cont.)

- Warmer layer about 2-3 meters thick
- Temperature 3 ~ 5°C higher than below
- Heat convection occurs only in the lower part
- Radiation level in hall will be greatly lowered.

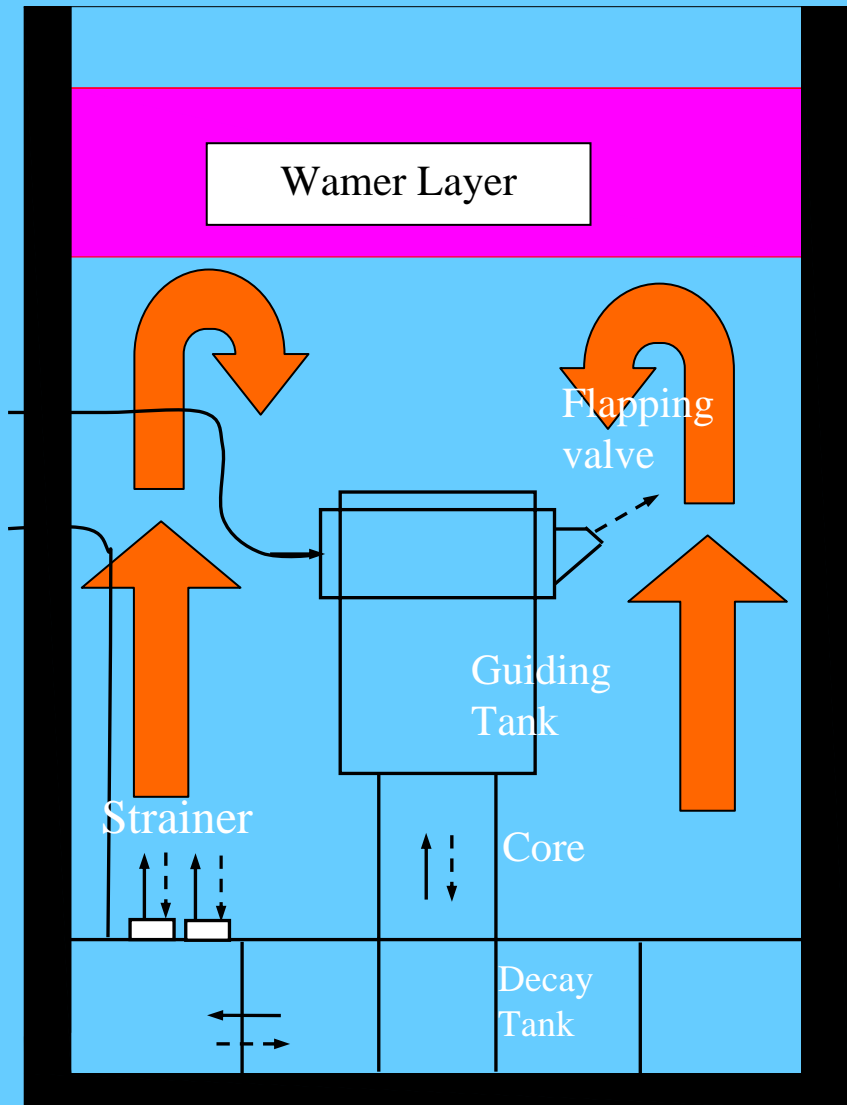



## 2.10 ECCS running along with reactor operating

CARR, PDO110P, FLA

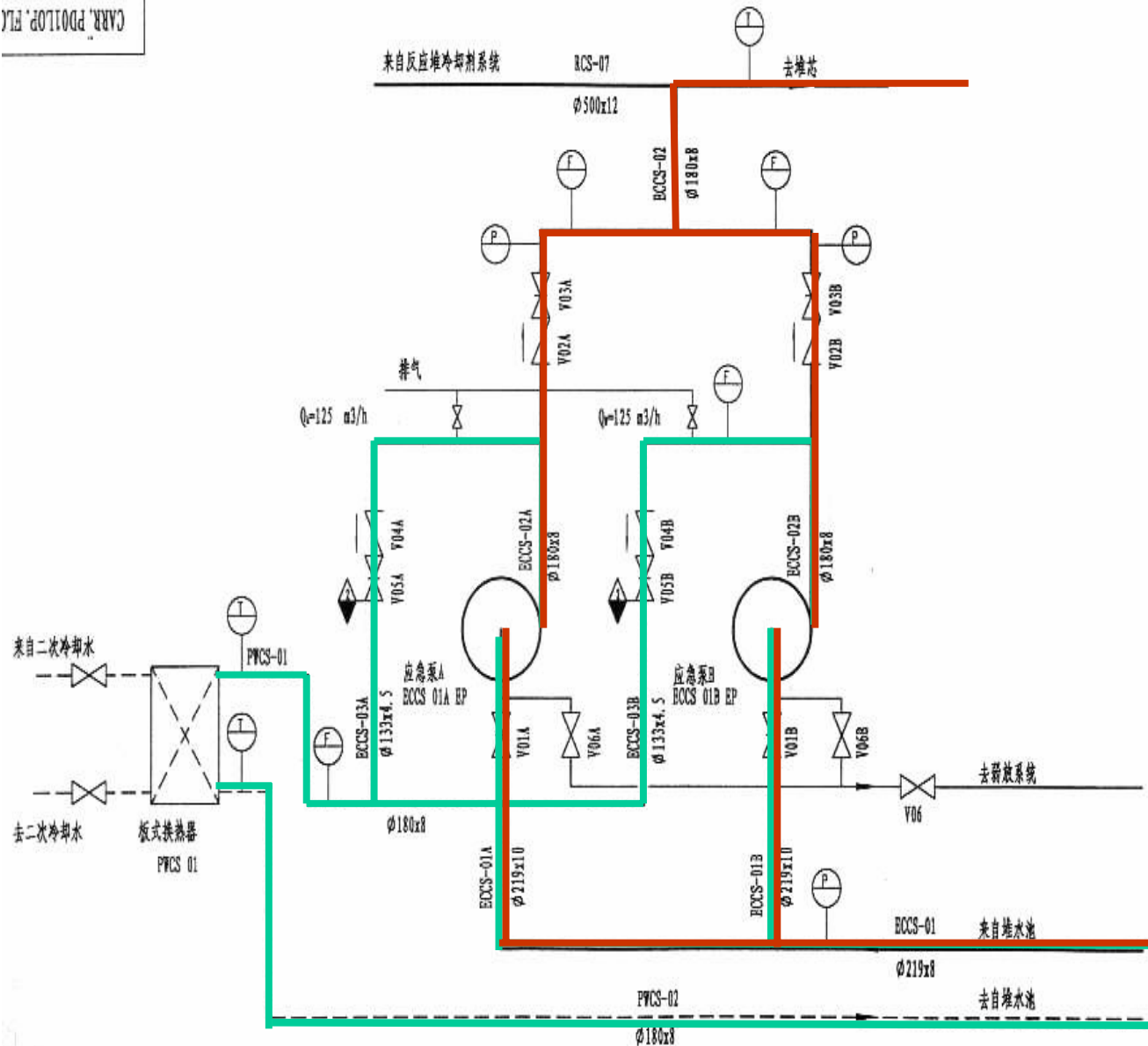

While the reactor is operating in normal, the function of ECCS is running only for pool water cooling.

When loss of coolant flow accident happen, pressure in primary pipe lowers, ECCS would be switched to core cooling mode passively, the pool water be pumped into core by the emergency pump to realize core cooling.



## **ECCS running along with reactor operating mode**

Due to higher failure probability for a not running device when it is demanded, the running mode of ECCS in CARR will avoid effectively such “put into running” failure.

Enhance the safety performance for CARR.



## 2.11 Radioactivity holding up mode during accidents

- Arguments about the emergency ventilation system design:  
releasing mode of radioactivity through the stack.  
low level releasing mode of radiation? or  
high elevated diffusing rule?
- Finally the radioactivity holding up mode was adopted:  
When radioactivity release accident happen, the normal ventilation system switched off, no emergency ventilation, radioactivity released holding up for a certain period.  
After a period of decay, the radioactivity will be gradually exhausted through the stack.





## Radioactivity holding up mode

- Obviously, the key point of this philosophy is:  
The requirement for the leakage rate of confinement should be strictly lowered, otherwise, the rad- release via the low level during the holding up period will impact the environment much and make the radiation dose beyond the regulation limit
- The leakage rate design of confinement well below a certain value, say, 2.5% volume of whole confinement per day



# 3 . Application design of CARR

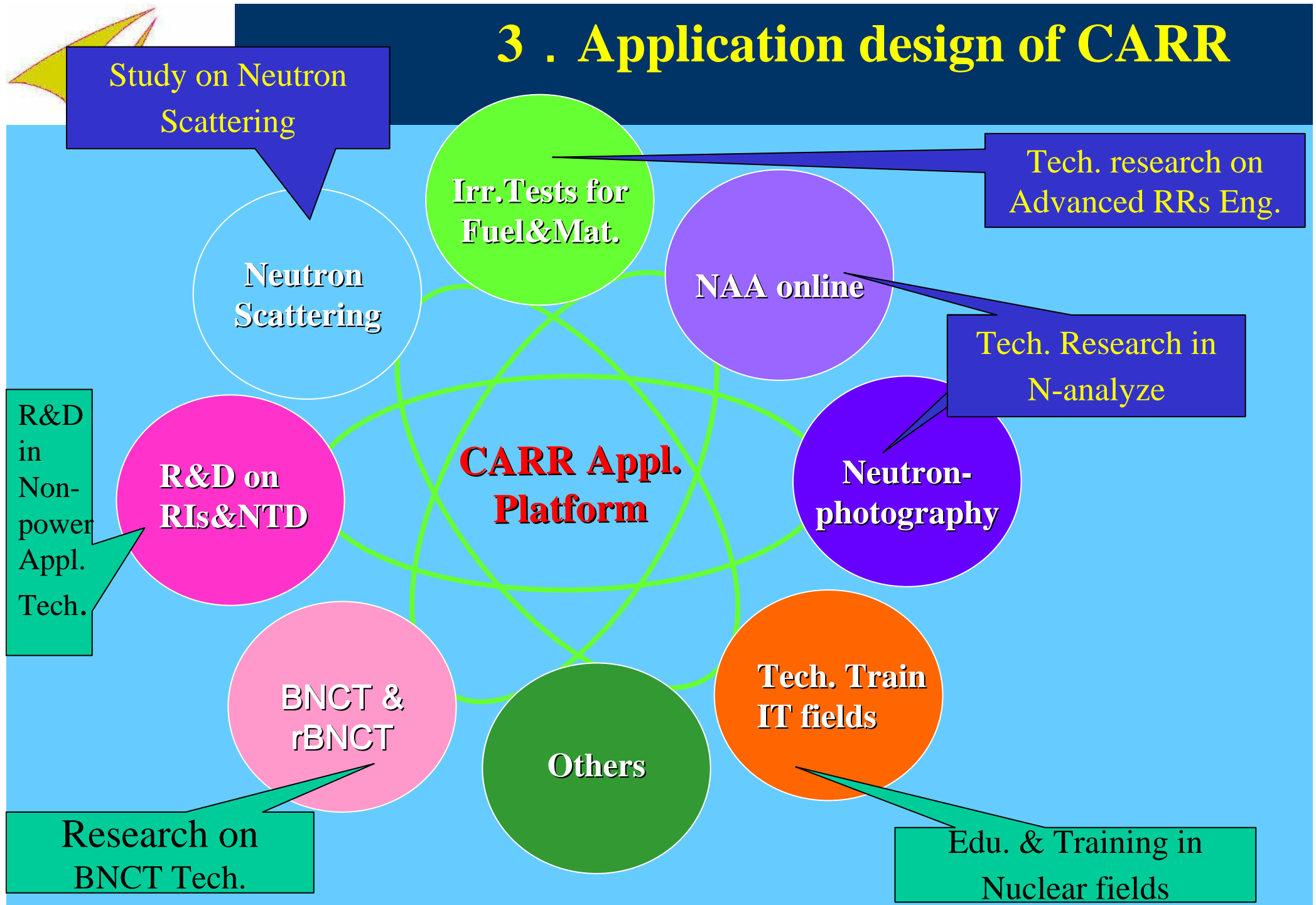



### 3. Application design of CARR

The erection of CARR synthetic application research platform will make great contributions to:

- nuclear fundamental science,
- reactor engineering techniques,
- industrialization in nuclear techniques application, and
- human resources cultivation in nuclear fields

for China.



## 4 . Conclusion

- CARR is a multipurpose research reactor with high performance.
- Its design philosophies, adoption of advanced technologies, arrangement in systems and components, adoption of operation mode, has always centered on a general aim, i.e., meritorious, safety and economics.
- Among these design properties, some belong to the first examples in China and even in the world.  
It reflects, to a certain extent, the design level for a research reactor in China.
- CARR is about to be put into operation and it will provide an important R&D platform for China Institute of Atomic Energy and make contributions to the development of nuclear science and technology, to needs of increasing national economics and peoples life in China.



## 5. Status of CARR project

- The reactor construction began on August 26, 2002
- Some key components have been seated to their positions, such as the water pool steel liners, decay tank located at the bottom of pool, pre-embedded frames for horizontal beam tubes, etc
- Key items of equipment being manufactured: guiding tank, core housing vessel
- Commissioning preparing job is progressing now
- The reactor will be first critical at the end of 2007



## Status of CARR project(2)



Aug.26,2002, Ceremony of CARR  
Project





## Status of CARR project(4)



**Full view of CARR site**



## Status of CARR project



Main structure of 05sub-item top cover finished





Installation for frame of Horiz. beam channels





Measuring the deformation for round welding of frame





Hoisting of the steel liner



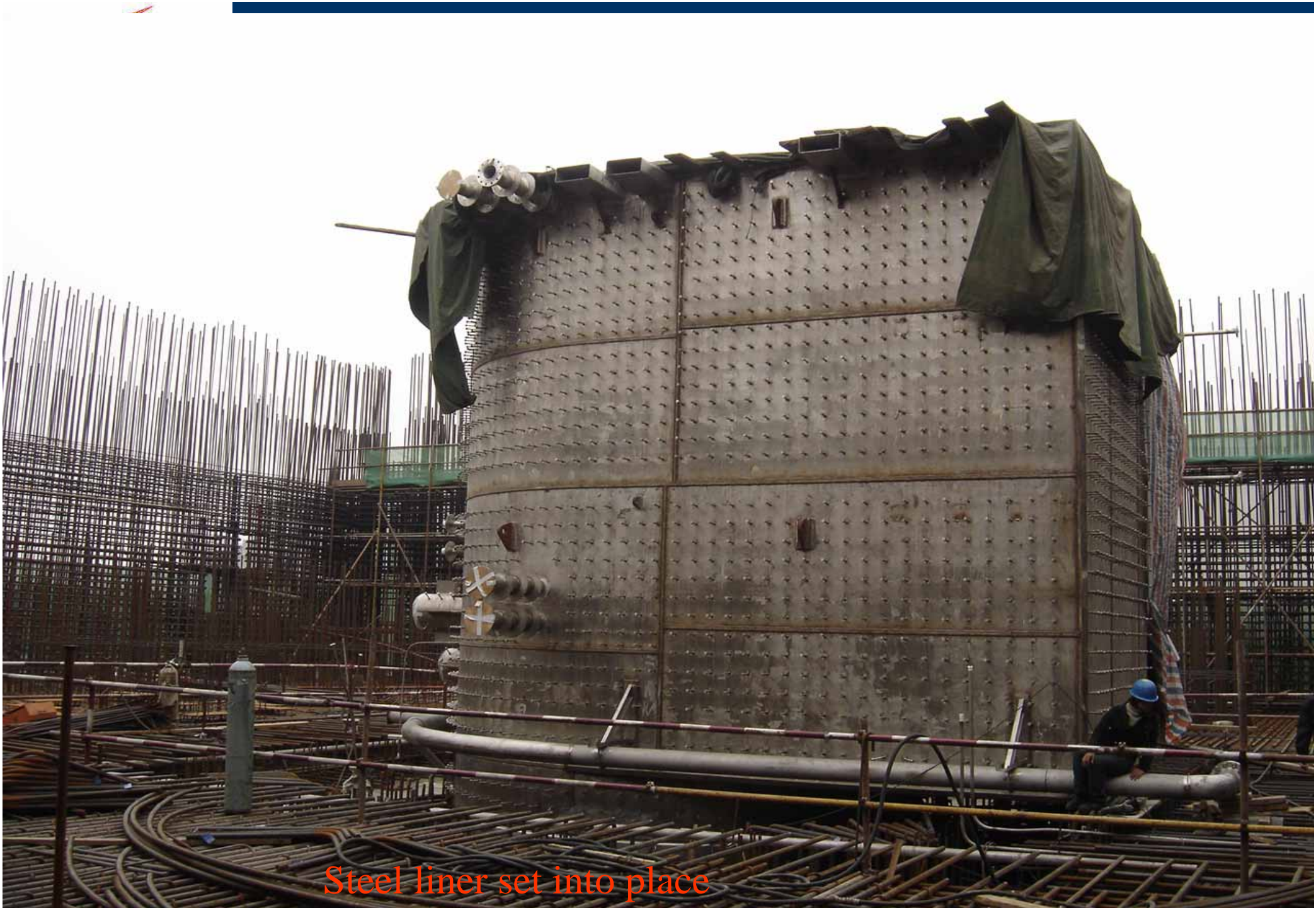

Steel liner set into place





Complete of steel liners welding

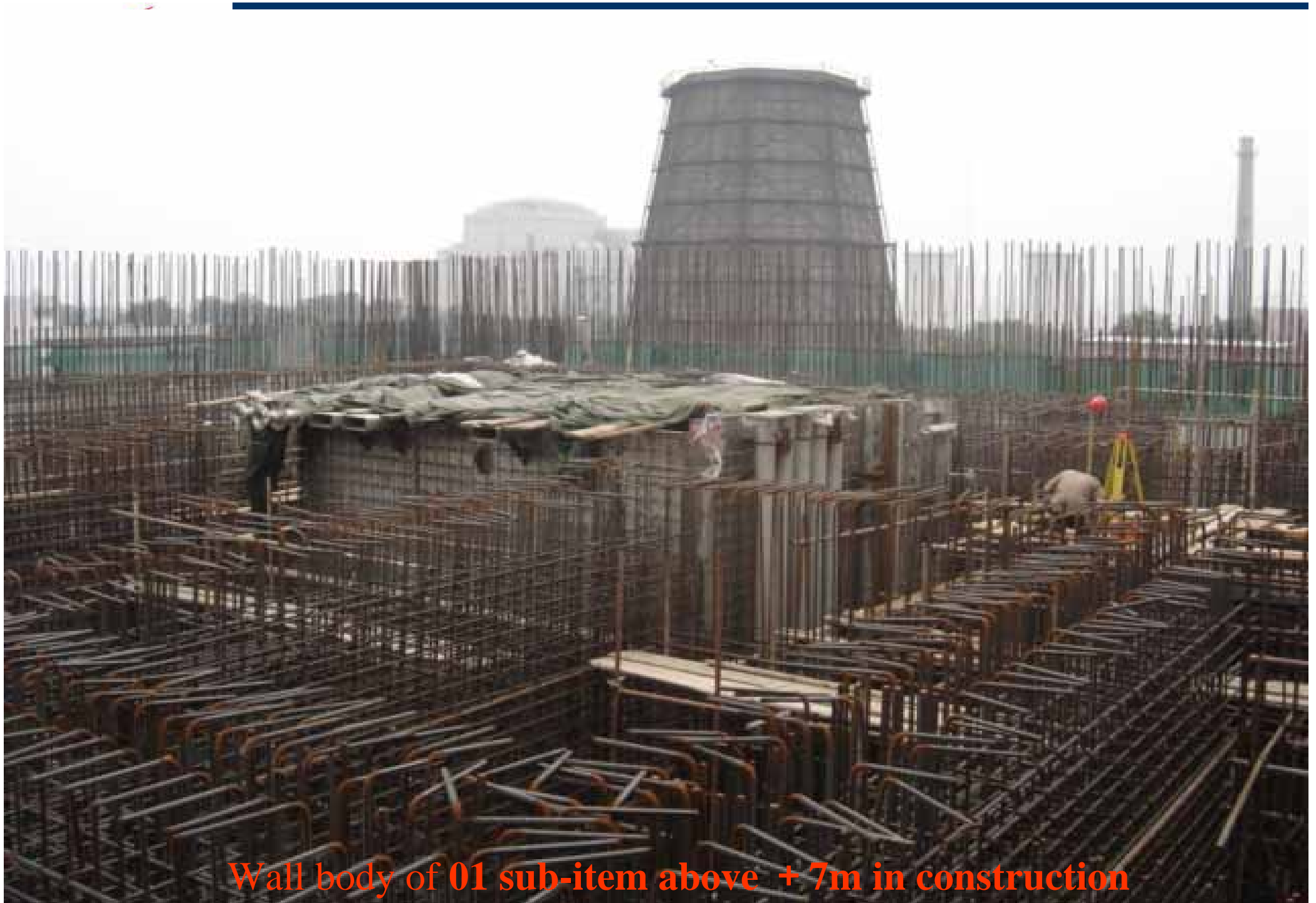

**Wall body of 01 sub-item above + 7m in construction**





Construction of neutron guiding hall started( 2005.4)





Outside view of neutron guiding hall





Low voltage cabinets set place in 03 sub-item( 2005.7)



Medium voltage cabinet installation of 03 sub-item( 2005.4)





Piping system installation of 03 sub-item( 2005.7)



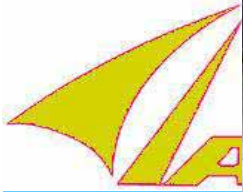

Tests on 6061 ( T ) Al core housing vessel( 2005.7)





Accepted meeting for DCS(2005.7)





**General manager Kang of CNNC inspects the CARR site( 2005.10)**





**Construction of cooling tower base( 2005.10)**



**Construction of hyperbola cooling tower +20m (2006.4)**





Completion of hyperbola cooling tower 60m(2006.8)



Dig break of 04 sub-item base





**Loading machine  
tests in factory**

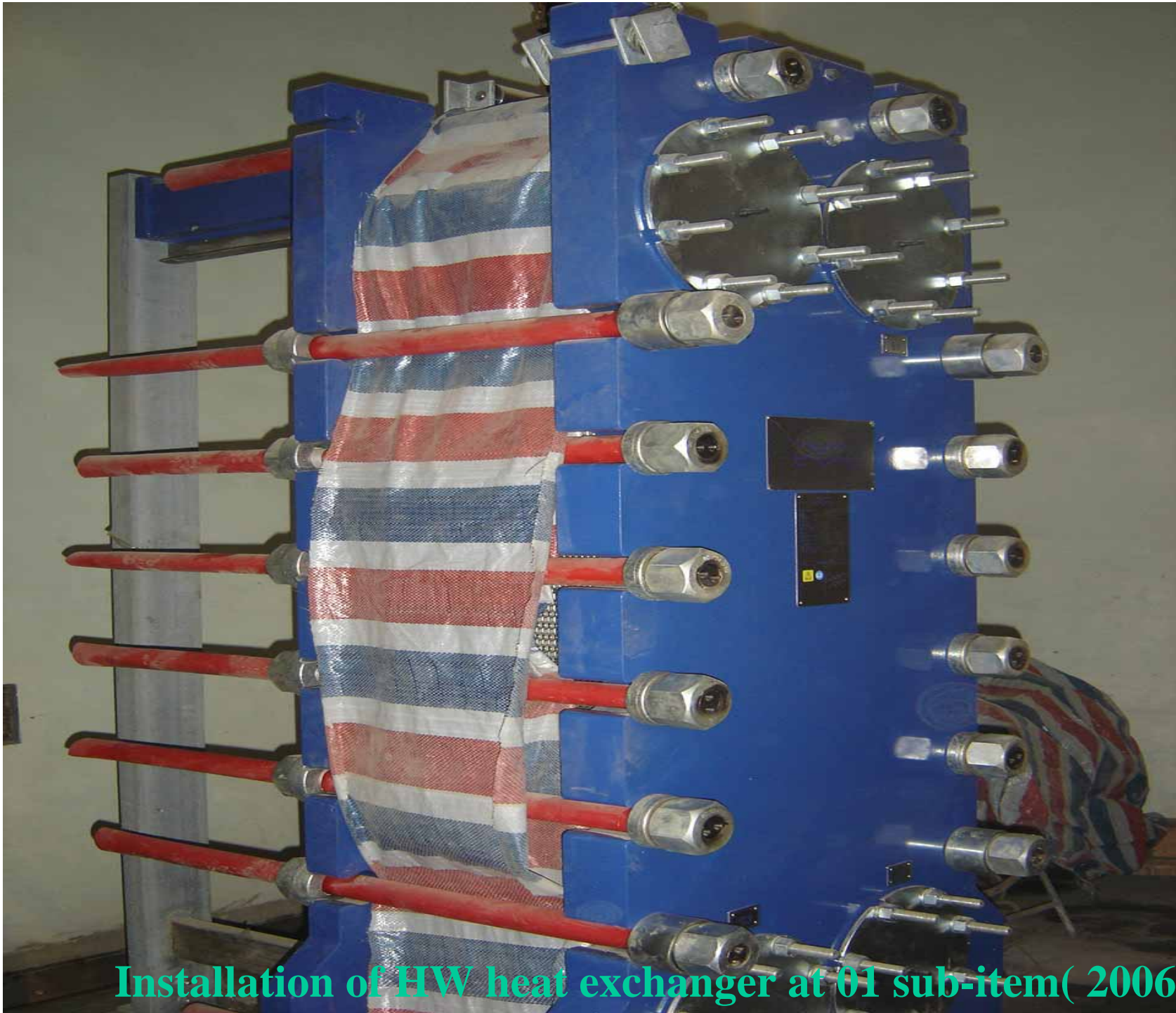

Installation of HW heat exchanger at 01 sub-item( 2006.4)







Crane set in place in operating hall



Installation of secondary loop piping





Top view of water pool



Ventilation stack seated



**THANKS A LOT  
FOR  
YOUR ATTENTION**